



## DPD80 1550nm Datasheet

Resolved Instruments Inc.  
[www.resolvedinstruments.com](http://www.resolvedinstruments.com)  
[info@resolvedinstruments.com](mailto:info@resolvedinstruments.com)

## General Description

The DPD80 is a low noise digital photodetector that measures the intensity of incident light at a sample rate of 80 MS/s. The data can be streamed directly to your computer through a USB 3.1 cable, which is also used to power the device. Our included software is freely downloadable from our website, <http://www.resolvedinstruments.com>, and allows you to acquire real-time data in either the time or frequency domain, eliminating the need for separate photodetectors, amplifiers, analog to digital converters, oscilloscopes, and spectrum analyzers in your experimental setup. In addition to our user interface you may automate data-taking with our Python and MATLAB libraries.

The DPD80 has a built-in antialiasing filter that can be switched on and off. When the filter is on the noise floor is reduced and frequencies above 40 MHz will be suppressed. When the filter is turned off, it allows the user to view signals above 40 MHz that are mapped from higher Nyquist zones to the first.

Another feature of the DPD80 is its two gain settings. The high gain mode minimizes noise while the low gain mode increases the dynamic range. These two gain modes differ by a factor of 4.

In addition to our user interface you may automate data-taking with our Python and MATLAB libraries. The connections on the DPD80 are summarized in the following table:

Connector	Description
USB 3.1 Type-C	Used to power the device and stream digital data to your host computer. If you are using the analog output and not the digital data the USB cable may be plugged into a USB wall plug to power the device.
Analog Output - SMA	This SMA outputs a voltage between 0V to 3V, linearly corresponding to the intensity of incident on the photodetector. This output allows the DPD80 to function as a drop-in low noise replacement for a typical analog photodetector.
A - MMCX	This is a general purpose 12-bit analog outputs that can generate voltages between 0 V to 3.3 V. The settling time of these outputs is 1 ms.
B - MMCX	This is a general purpose digital output with PWM capability
Trig, Sync - MMCX	These are two digital inputs / outputs that can be used to trigger data-taking of the DPD80 or to synchronize the DPD80 with other instruments.

## Absolute Maximum Ratings

Parameter	Rating
Optical input power	5 mW
Voltage trigger input	0 V to +3.3 V
Voltage sync input	0 V to +3.3 V

# Specifications

## General Specifications

Parameter	Value	Figure
Wavelength sensitivity	900 nm - 1630 nm	10
Peak responsivity	0.95 A / W <sup>1</sup>	
Coupling	Free space ball lens or fiber coupled (APC)	
Photodiode active area diameter	80 μm	
Ball lens diameter	1.5 mm	
Power source	USB 3.1 Type-C	
Trig, sync logic high	> 2.15 V	
Trig, sync logic low	< 0.82 V	

## Digital Data Specifications

Parameter	Value	Figure
Minimum NEP high gain mode	1.5 pW / √Hz	1, 2
Minimum NEP low gain mode	3.3 pW / √Hz	3, 4
Saturation power high gain mode	35 μW	5
Saturation power low gain mode	140 μW	8
Anti-aliasing filter bandwidth	35 MHz	9
Digital bandwidth with aliasing	100 MHz	9
ADC sampling rate	80 MS/s	
ADC vertical resolution	14 bit	
Data output port	USB 3.1 Type-C	

<sup>1</sup> For more information on the photodiode please refer to part number g6854-01 in the hamamatsu datasheet [https://www.hamamatsu.com/resources/pdf/ssd/g6854-01\\_kird1013e.pdf](https://www.hamamatsu.com/resources/pdf/ssd/g6854-01_kird1013e.pdf)

### Analog Output Specifications

Parameter	Value	Figure
Minimum NEP high gain mode	$1.5 \text{ pW} / \sqrt{\text{Hz}}$	
Minimum NEP low gain mode	$3.3 \text{ pW} / \sqrt{\text{Hz}}$	
Analog saturation power high gain mode	$35 \text{ } \mu\text{W}$	7
Analog saturation power low gain mode	$140 \text{ } \mu\text{W}$	8
Analog bandwidth	100 MHz	9
Analog output gain in high gain mode	$80 \text{ kV} / \text{W}$	7
Analog output gain in low gain mode	$20 \text{ kV} / \text{W}$	8
Data output port	SMA	
Analog output impedance	$50 \text{ } \Omega$	

## Typical Performance Characteristics

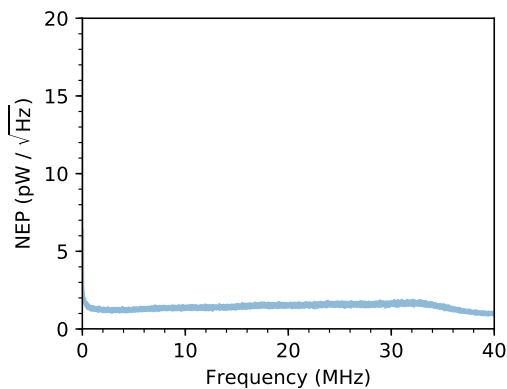

Figure 1: Digital noise floor at 1 kHz BW. High gain mode.<sup>2</sup>

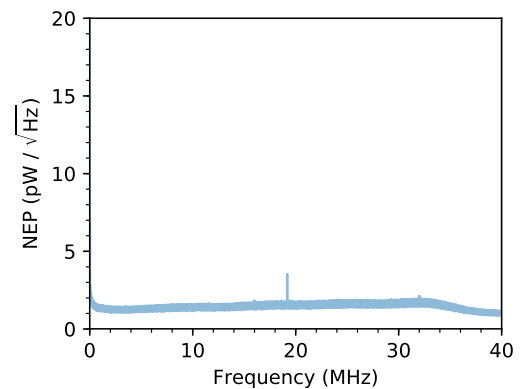

Figure 2: Digital noise floor at 10 Hz BW. High gain mode.

<sup>2</sup> All noise spectrums are single sided.

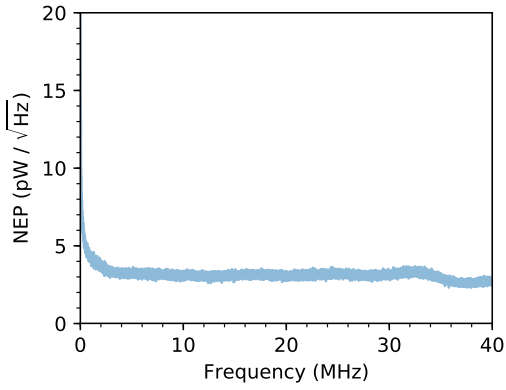

Figure 3: Digital noise floor at 1 kHz BW. Low gain mode.

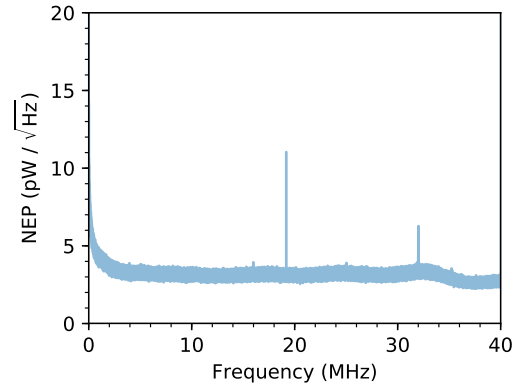

Figure 4: Digital noise floor at 10 Hz BW. Low gain mode.

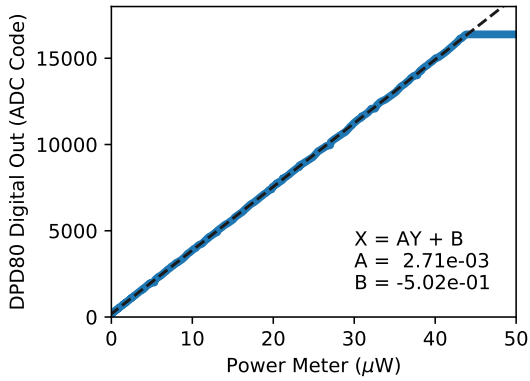

Figure 5: Digital ADC power calibration. High gain mode.

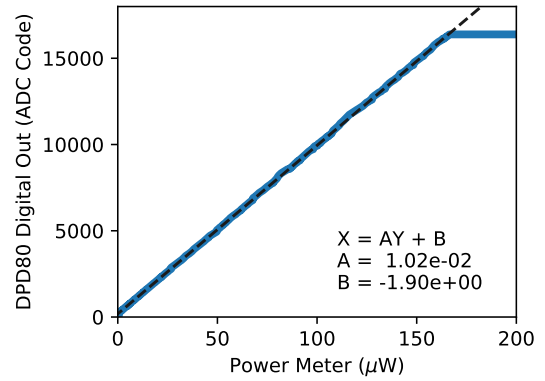

Figure 6: Digital ADC power calibration. Low gain mode.

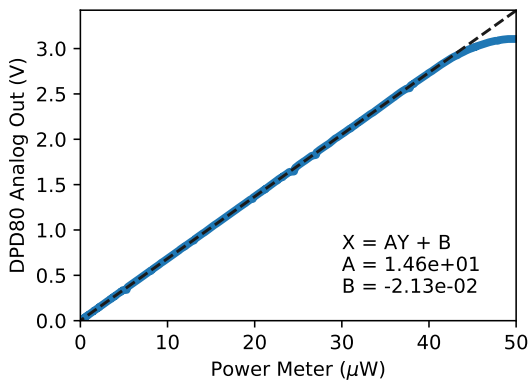

Figure 7: Analog output power calibration. High gain mode. <sup>3</sup>

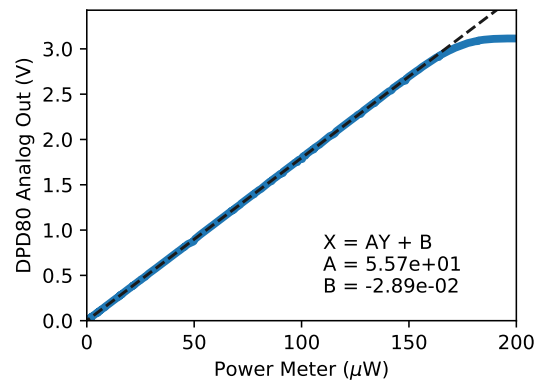

Figure 8: Analog output calibration. Low gain mode. <sup>3</sup>

<sup>3</sup> When measuring the analog output voltage with a 50 Ω terminated input, the voltage measured will halved.

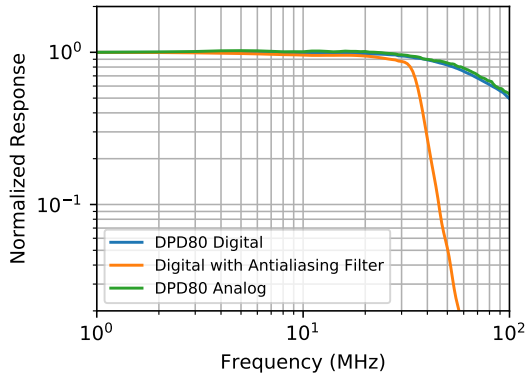

Figure 9: Frequency response of the DPD80. <sup>4</sup>

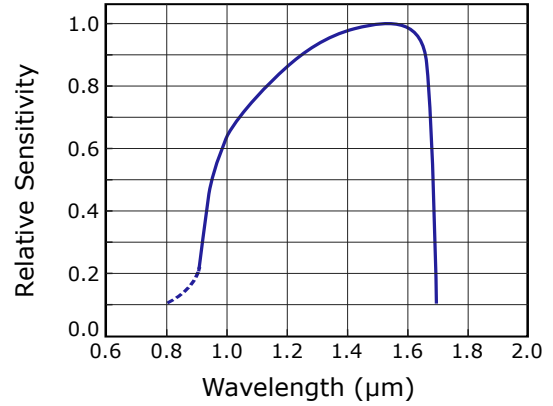
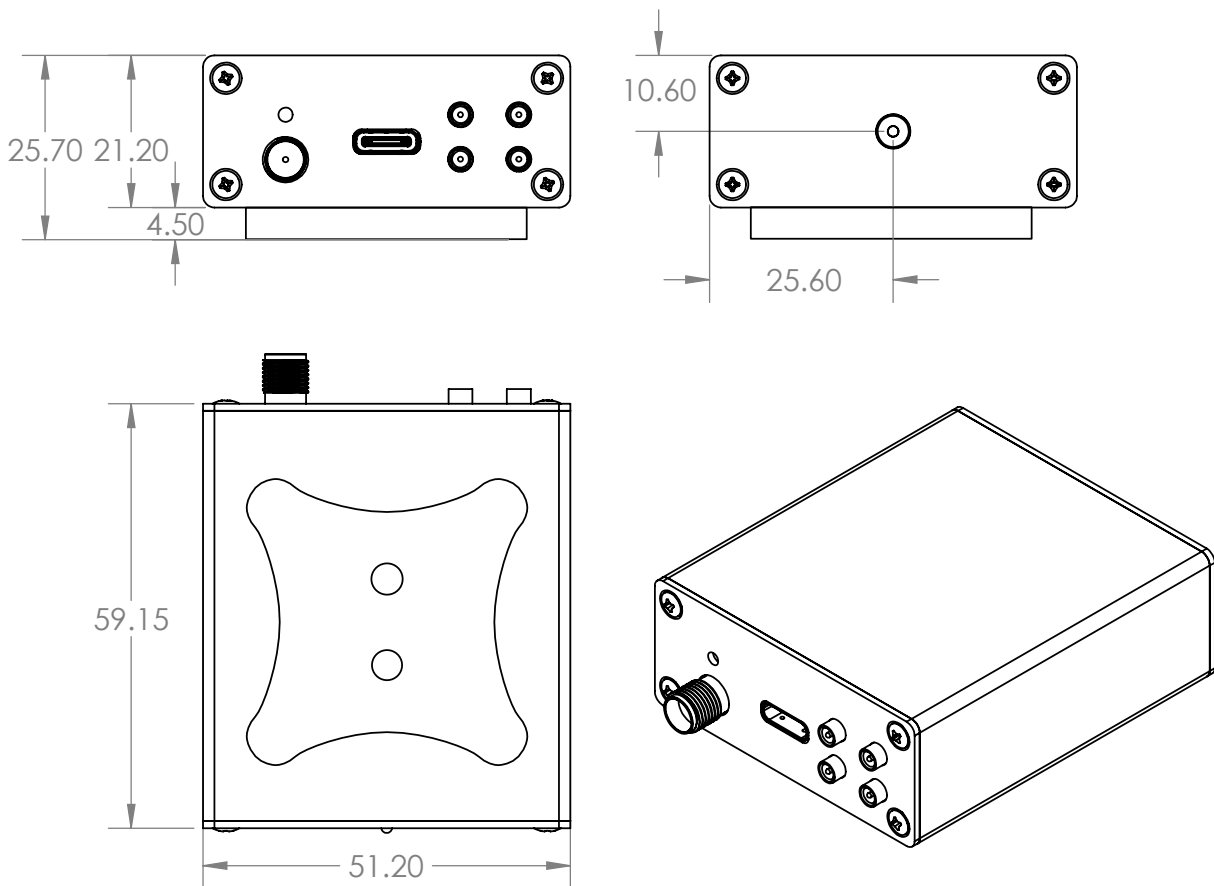

Figure 10: Spectral sensitivity

## Dimensions



All dimensions are in millimeters.

<sup>4</sup>Frequencies above 40 MHz are aliased when taking digital measurements.